

Medium Sized Wooden Packing Crate

General Assembly Instructions

Do take time to read through the instructions and understand how the parts fit together before reaching for the glue pot. Where ever possible parts have been designed to be symmetrical but occasionally parts have to be left or right handed so take care to follow the instructions carefully at these points.

Most parts are attached to their frets by small sections of half cuts. To remove parts either cut through the remaining material from the front with a thin sharp blade (e.g. a scalpel) on a cutting mat or turn the whole fret over and with the aid of a steel ruler aligned with the pieces side, cut lightly with a knife to break through the remaining wood.

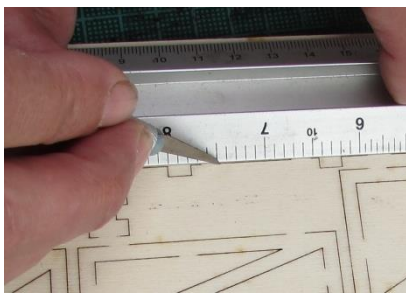

Gluing

Wood and MDF parts may be glued with PVA wood glue, Cyanoacrylate adhesive (super-glue) or epoxy resin (Araldite). Beware of very cheap glues, their joints may fail! If you do use a “super-glue”, go for one which takes a few seconds to set rather than an instant “grab” one. This will give you a few seconds to adjust the parts position before it is too late.

Painting

This is very much a matter of personal choice. As poplar plywood is used for this kit, leaving the model mostly unpainted can be very attractive however if you plan to run your trains in all weathers, some form of protection (especially on the MDF parts) will be needed; a couple of coats of acrylic matt varnish from a “rattle can” is easy way of achieving this.

Packing Crate Assembly

Step 1

Fit two sides to the bottom (either of the pieces marked with fragile). Ensure the lettering on the long side is the right way up and on the outside. Run a small bead of super-glue into the internal corners to fix permanently.

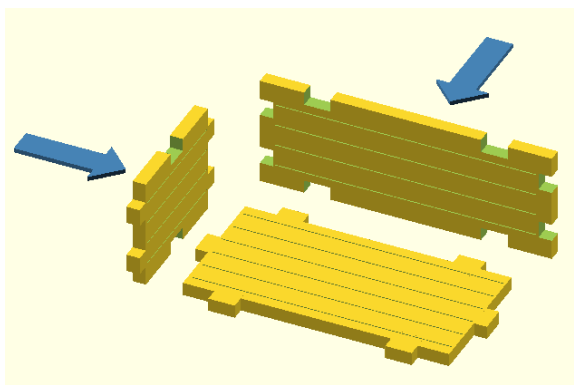
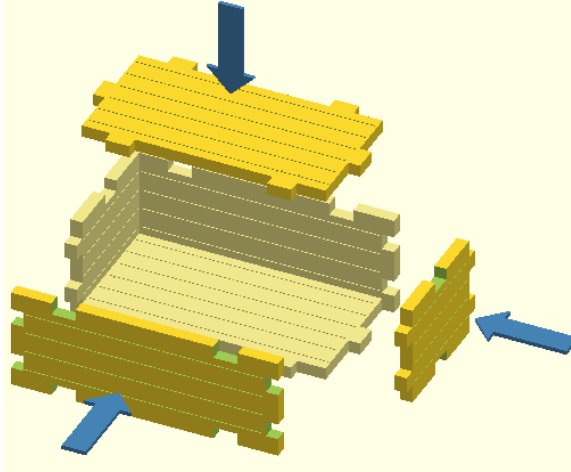

Step 2

Now fit the other 2 sides (ensuring lettering is right way up). Again super-glue the sides from the inside. Fit the lid and run a little glue into the joints. Once the glue is dry, run a file over all the outside corners to ensure none of the tab ends are proud of their surroundings.

Step 3

Glue the side braces on to the long sides, ensuring the lettering is not obscured.

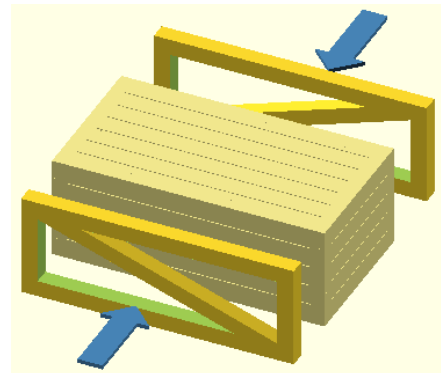
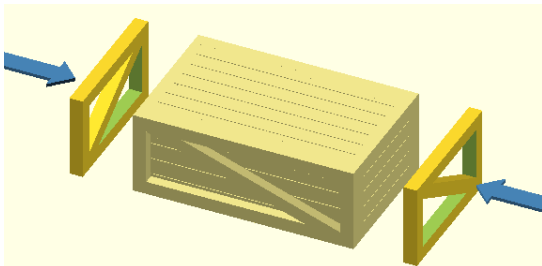

Step 4

Glue the end braces on.

Step 5

Glue the lid brace on ensuring the lettering is not obscured.

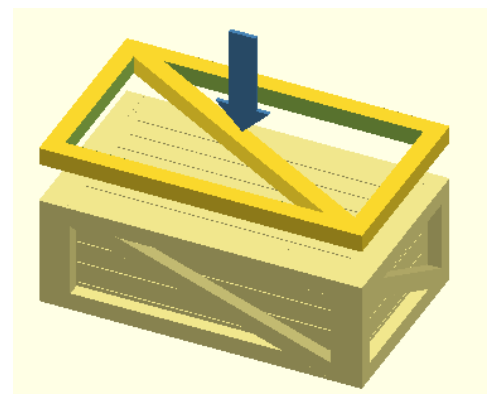

JOB DONE !