

Southwold Railway Goods Wagon 7/8 scale 32mm / 45mm gauge

This model is based on the four wheel open goods wagons used by the Southwold Railway. The kit features 3D printed nylon details and running gear and quality steel wheels.



General Assembly Instructions

Do take time to read through the instructions and understand how the parts fit together before reaching for the glue pot.

Most parts are attached to their frets by small sections of half cuts. To remove parts either cut through the remaining material from the front with a thin sharp blade (e.g. a scalpel) on a cutting mat or turn the whole fret over and with the aid of a steel ruler aligned with the pieces side, cut lightly with a knife to break through the remaining wood.

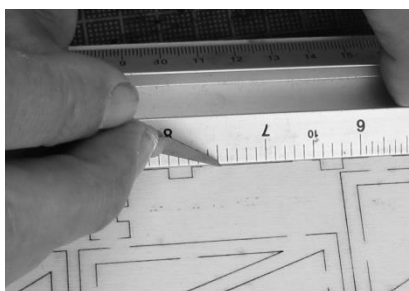

DO NOT simply try and twist the parts out of the fret, there is a risk that the part may tear. The laser cutting process will leave a degree of edge discolouration. If you plan to leave your model unpainted now is the time to lightly sand the edges to remove this discolouration.

Gluing

Wood and MDF parts may be glued with PVA wood glue, Cyanoacrylate adhesive (super-glue) or epoxy resin (Araldite). Beware of vary cheap glues, their joints may fail! If you do use a “super-glue”, go for one which takes a few seconds to set rather than an instant “grab” one. This will give you a few seconds to adjust the parts position before it is too late.

Nylon parts (e.g. the mounting lugs) are best fixed with a multi-purpose contact adhesive.

Painting

This is very much a matter of personal choice. As poplar plywood is used for the body, leaving the model mostly unpainted can be very attractive however if you plan to run your trains in all weathers, **some form of protection (especially on the MDF parts) will be needed**; a couple of coats of acrylic matt varnish from a “rattle can” is easy way of achieving this.

Tools

The following tools will be required:

- A sharp modelling knife or scalpel
- A long nosed pair of pliers
- A small cross point screwdriver
- A small file, glass paper or an emery board “nail file”

The following tools are recommended

- A cutting matt
- A small steel ruler
- Some small clamps, bulldog clips or rubber bands
- A round section “needle file”
- A pin or 1mm drill bit
- A clean “medium” tooth brush
- A 6mm spanner
- A fine tipped black permanent marker pen.

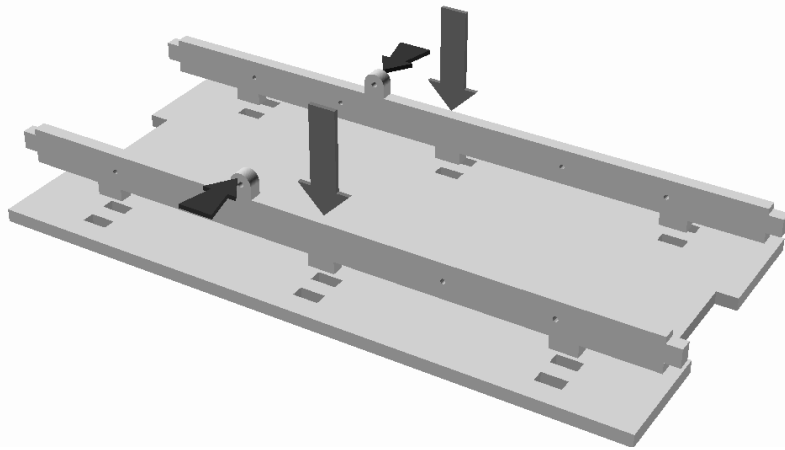

Step 1

Glue the 2 MDF inner sole-bars into the locating sockets of the MDF under floor. The inner hole sets are for 32mm gauge and the outer set for 45mm gauge. Make sure that the brake hangers are opposite each other as indicated. Make sure the parts are squeezed together properly. Wipe out any glue that oozes out of the joints.

Step 2

Glue the two MDF buffer beams onto the sole bar lugs. The parts should fit together snugly but if necessary lightly file the lug edges if the fit is too tight.

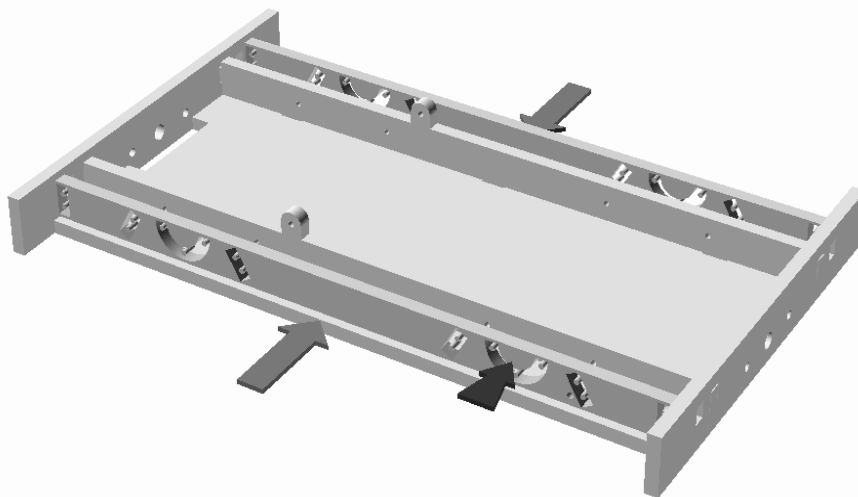
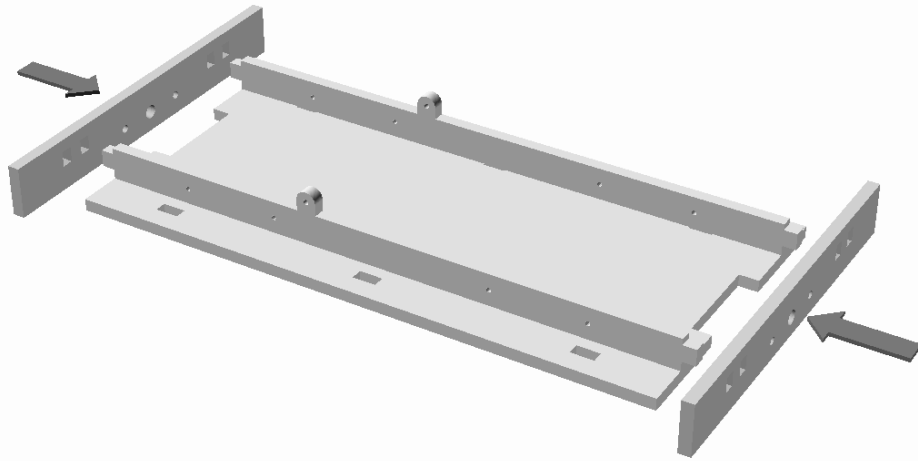

Step 3

Glue the 2 plywood outer sole bars on the outer faces of the MDF solebars.

Note orientation of engraved reinforcement strips

Once the glue has set, now's a good time to paint or seal with varnish the completed chassis!

Step 4

First check the axle box hole is free of printing dust. This is best done by gently “twizzling” a 3mm flat bladed screw driver or drill bit in the hole. Check that the axle journal rotates freely in the hole.

Screw an axle guard onto one sole bar’s inner face. You will find a pair of correctly spaced pilot holes. Only **HALF TIGHTEN** the screws for now, you will need quite a bit of “play” to allow you to get the opposite axle guard fixed.

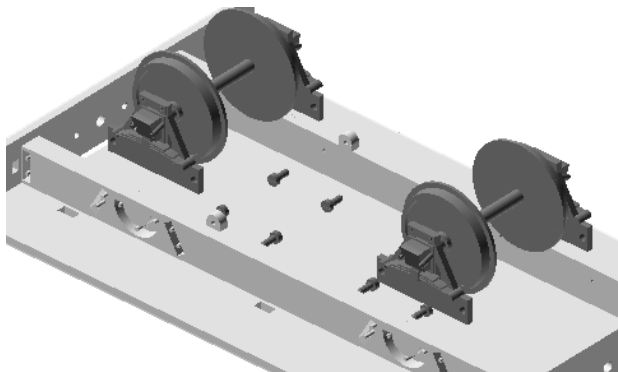
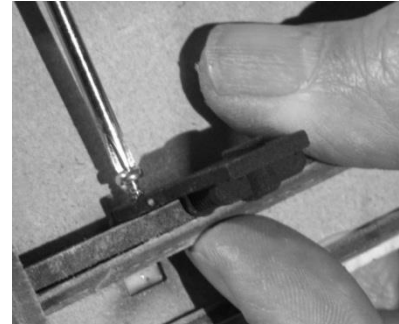

Fit the opposite axle guard to a wheel journal and then thread the opposite journal into the “semi-fixed” axle guard. Now gently manoeuvre the unfixed axle guard into position. Fasten in position with two more screws (do make sure they go into their pilot holes). Tighten up the screws on the first axle guard.

Give the wheels a flick, they should spin freely. Repeat for the other wheelset. Add a drop of light oil (e.g. 3in1) before the wagon enters service.

Step 5

Thread a brake rod (two are provided to cater for either 45mm or 32mm gauge); through a brake hanger; through the two shoes and out through the other brake hanger. The rod should be almost flush on the side where the brake ratchet’s locating hole is at the “brake end” (see photo) and should protrude 6mm about the other side.

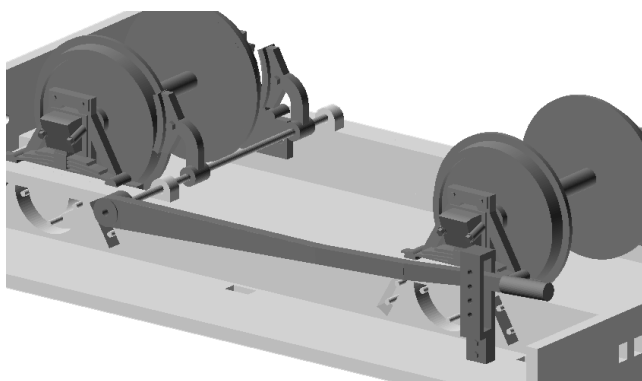
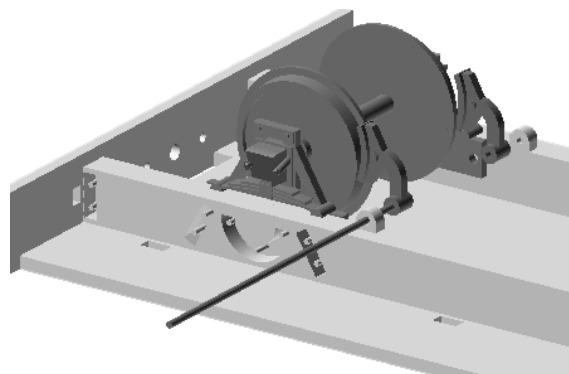

Thread the handle of the brake lever through the ratchet and push the boss onto the brake rod. Secure the ratchet onto the sole bar with a spot of glue. Twist and align the two brake shoes so they are aligned with the wheels but not touching them.

Step 6

Glue the 2 floor edge trims in place

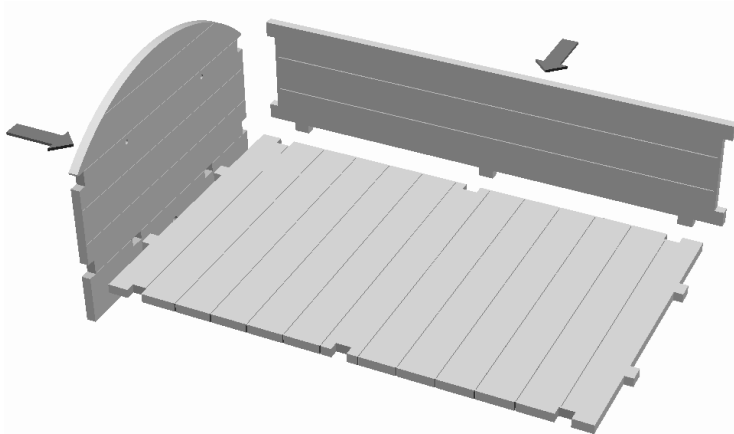
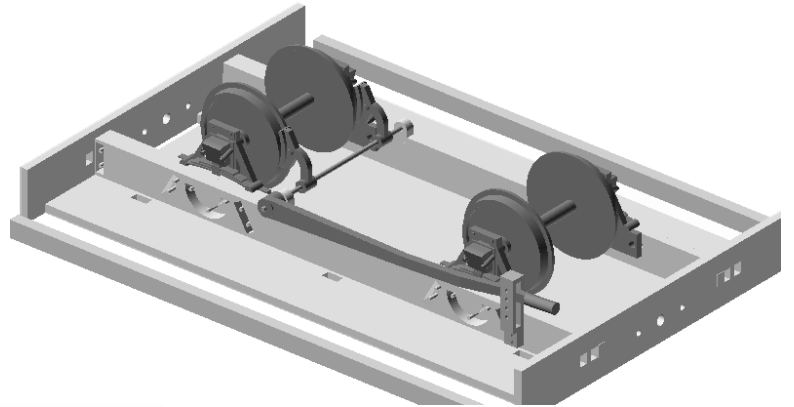

Step 7

Now glue an end and side to the plywood floor

Glue the other side and end in place. Stand the completed body on a flat surface, pass a large rubber band around it or lightly clamp and allow the glue to set

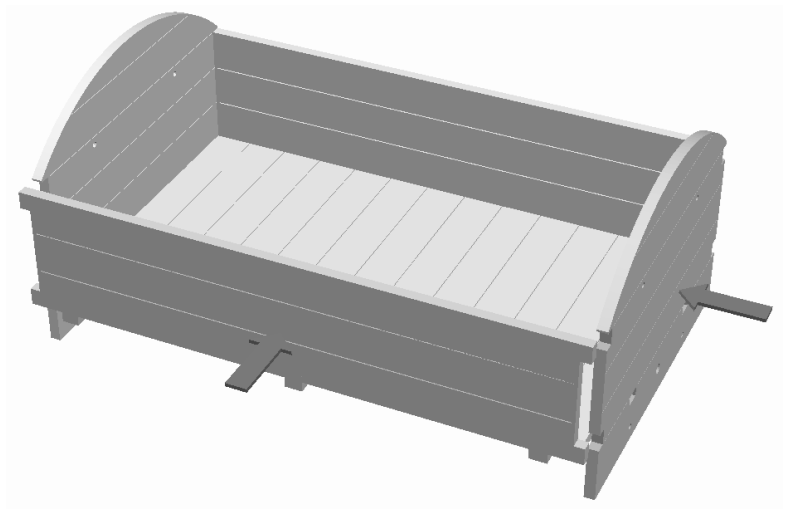

Step 8

Locate the 2 pairs of end-stanchions and cut through the two square sections joining the 2 parts together. If necessary clean any printing dust off the "castings" with a toothbrush.

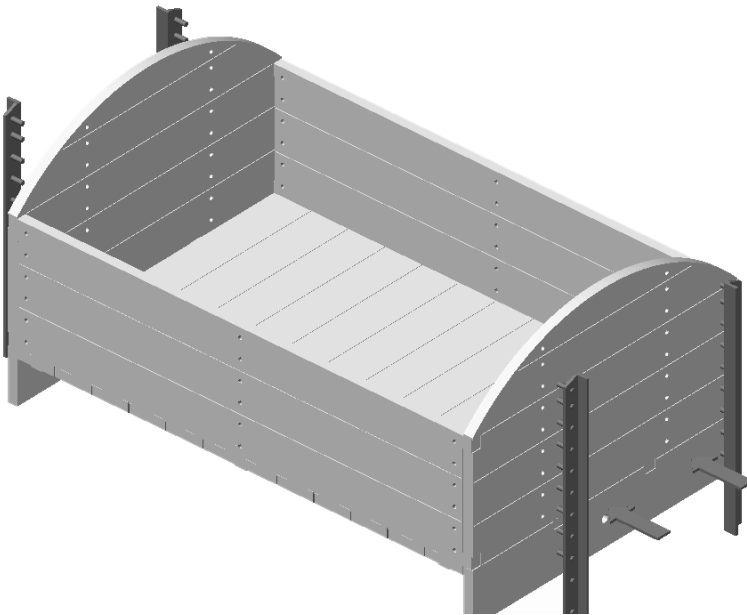
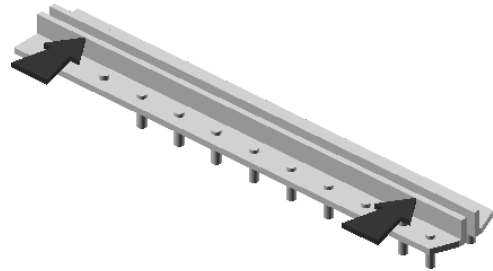

Glue the stanchions to the body ends, pushing the lines of "rivets" through the lines of holes in the body work

Step 9

Cut the four end door hinges (NB there are 2 left and 2 right handed hinges) from the "casting" and clean off the "sprues". Cut and trim the four latch pins and insert the pin into the straps hole as shown.

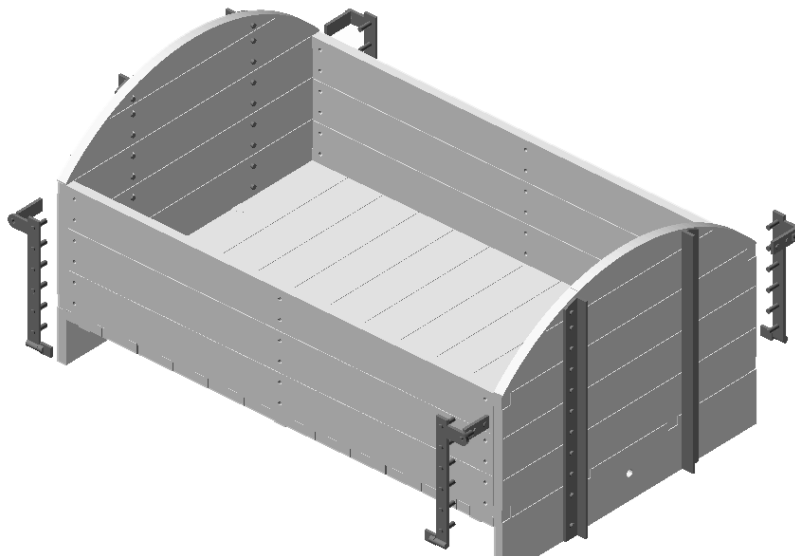
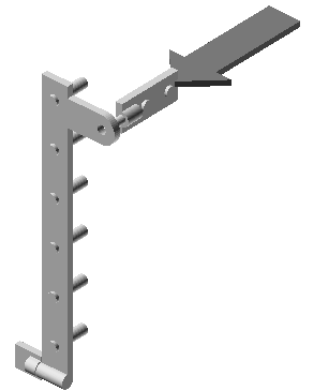

Glue the four hinge assemblies in place, again threading the "rivets" through the holes in the bodywork.

Step 10
Glue the two centre hinges
onto the body sides as
shown.

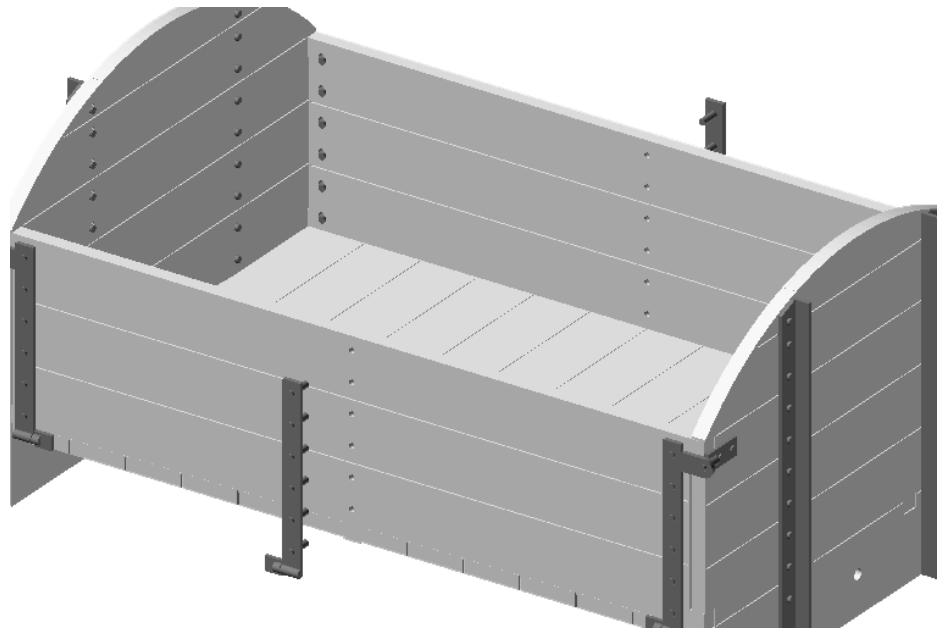

Step 11

Finally place the body on the chassis and fit the centre buffers. Thread the buffer's bolt through hole in the buffer beam, add the washer and screw on the nut. Ensure that hook is pointing straight up and tighten the nut (preferably with a 6mm spanner).

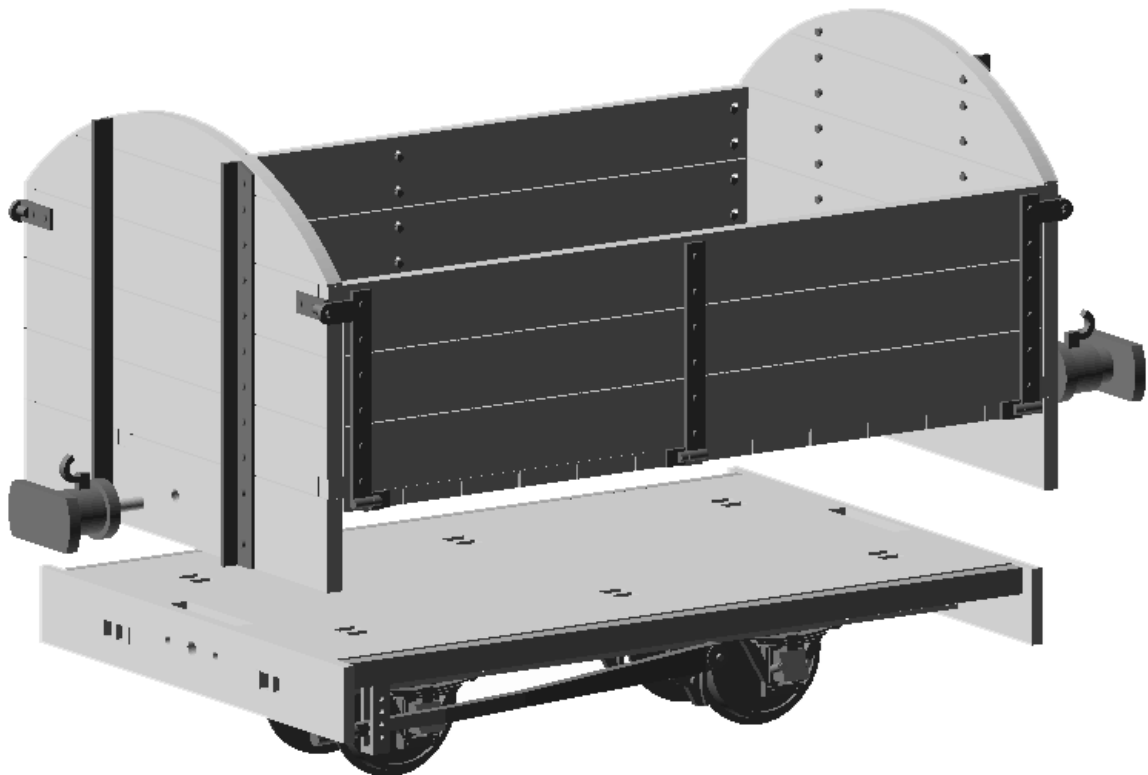

Finished!

Parts List

Part	Material	Quantity	
Chassis fret	MDF	1	
Floor fret	Plywood	1	
Sides fret	Plywood	1	
Ends fret	Plywood	1	
<i>Details Bag</i>			
Door hinge set	Nylon	1	
End stanchion pair	Nylon	2	
Brake lever	Nylon	1	
Brake shoe pair	Nylon	1	
Axle guard pair	Nylon	2	
M2 self tapper screws		8	
1.5mm dia Rod (80 mm long)	Steel	1	
1.5mm dia Rod (70 mm long)	Steel	1	
Wheel set	Steel	2	