

Darjeeling Himalayan Railway Goods Van



This model is based on the steel open wagons built at Tindharia works on the Darjeeling Himalayan Railway in India. Their design was largely based on the Leeds Forge wagons imported in the early 1900s but were fabricated from steel section and plate rather than the originals drop forging.

General Assembly Instructions

Do take time to read through the instructions and understand how the parts fit together before reaching for the glue pot.

Gluing

Most of this kit is 3D printed nylon which needs a good quality Cyanoacrylate adhesive (super-glue). The main body parts are laser cut styrene sheet which are best stuck with liquid styrene cement (e.g. MEK) but the super glue works OK as well. The three MDF chassis parts can be stuck with PVA wood glue, epoxy resin or super glue.

Painting

This is very much a matter of personal choice. Most of this kit is styrene sheet so any of the usual modelling paint will work well however we find auto car paints in aerosols work very well as well. The key to any type of paint is to ensure you apply a grey or matt red primer first.

Tools

The following tools will be required:

- A sharp modelling knife or scalpel
- A pair of side cutters for cutting nylon parts off their sprues
- A long nosed pair of pliers
- A small cross point screwdriver
- A small file, glass paper or an emery board "nail file"
- 1.5mm and 2mm drill bits

Step 1 – Nylon component preparation

All the nylon components in this kit have been sprued together to reduce costs and ease packing. The parts will need separating before assembly, this is best done with a sharp pair of side cutters but a sharp modelling knife will suffice. In the following diagrams the dark grey areas are the sprues to be removed.

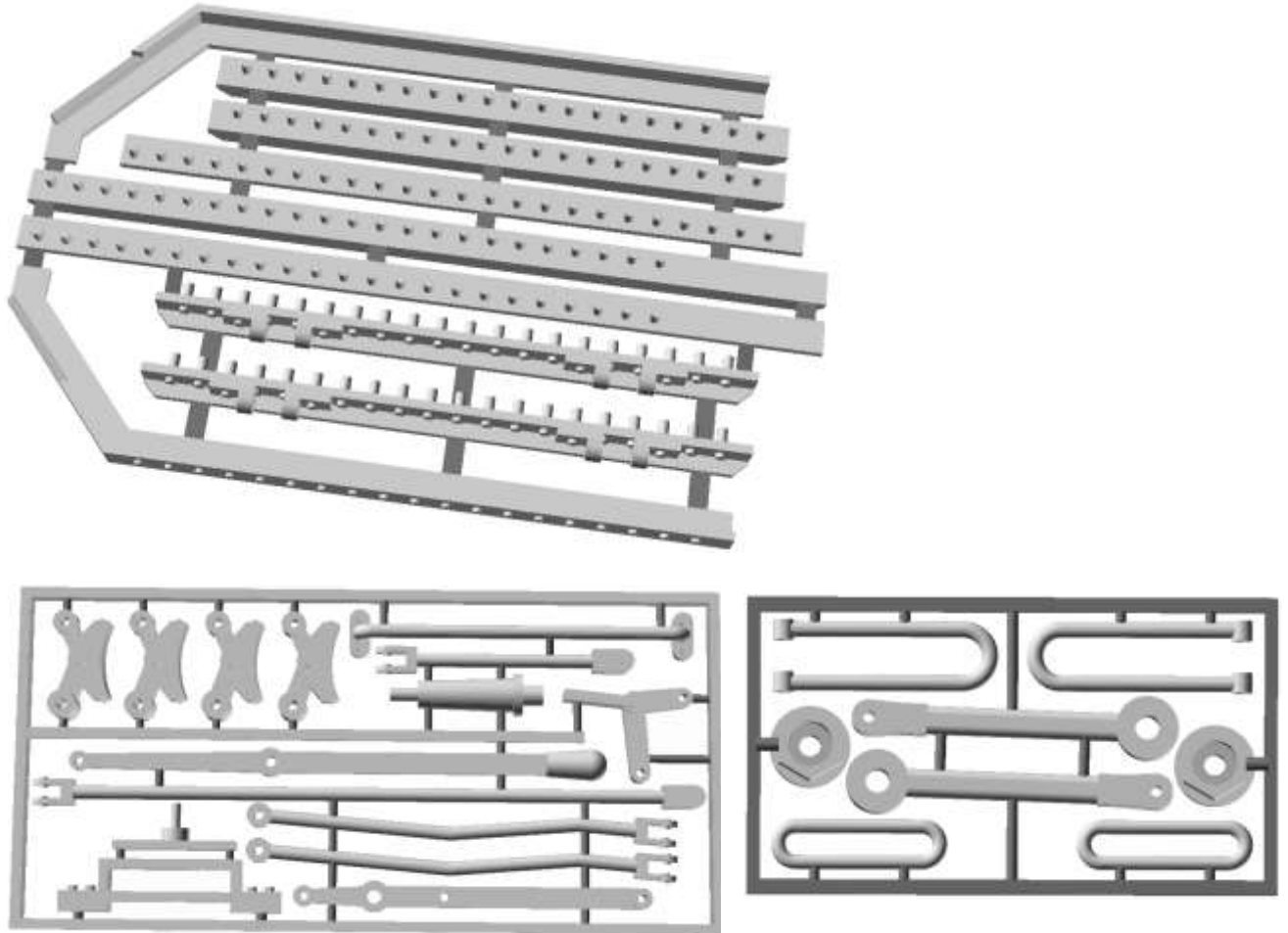

Removing the sprues from the black components will leave white patches where cut which are best “coloured in” with a black permanent marker pen.

Solebar preparation

The two solebars are printed using a different technique. This may leave a little lip on the inside face of the component. File this off with the supplied emery board as it is important the solebars fit flat on the chassis floor.

Step 2 – Chassis

Insert four M2 nuts into their sockets in the plastic sole bars. Ensure they are seated at the bottom of the sockets.

TIP: temporarily push a M2 bolt through the hole from the other side, thread the nut on and tighten into the hole with a screw driver.



Glue four small “nut cover plate” in place to trap the nuts. “Twizzle” a 1.5mm drill bit in the brake hanger holes so that the steel brake shoe rods fit.

Repeat for the other sole bar.

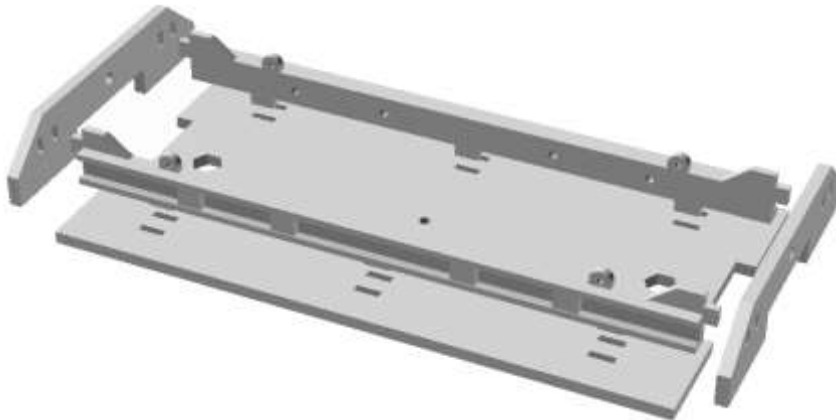

Glue the two sole-bars into the locating sockets of the MDF under floor. The inner sockets are for 32mm gauge and the outer set for 45mm gauge. Glue the two MDF buffer beams onto the sole bar lugs.

Thread the two M2.5 screws through the black nylon pivot mounts. Glue the mounts into the hexagonal holes in the chassis floor.

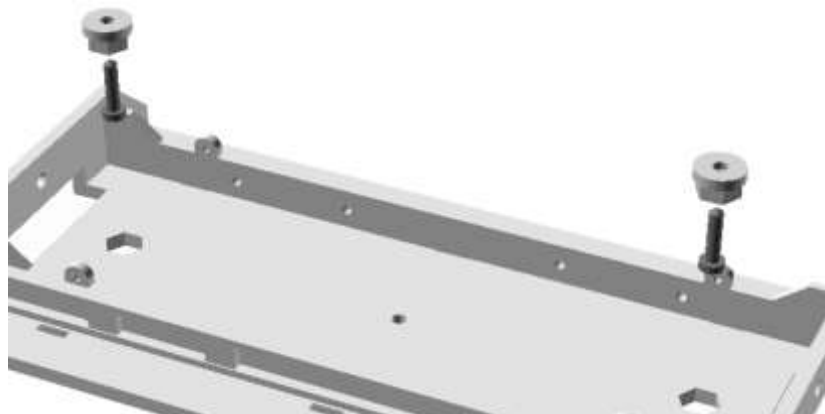

Once the glue has set, now's a good time to paint or seal with varnish the completed chassis!

Step 3 – Wheels and Optional Brakes

First clean out the axle holes in the axle guards by “twizzling” a 2mm drill bit in them and apply a drop of light oil (e.g. “3in1”) in the holes.

Fit the wheels and axle guards to the chassis. The axle guards are bolted in place with the eight 6mm long M2 screws. Check the wheels spin freely.

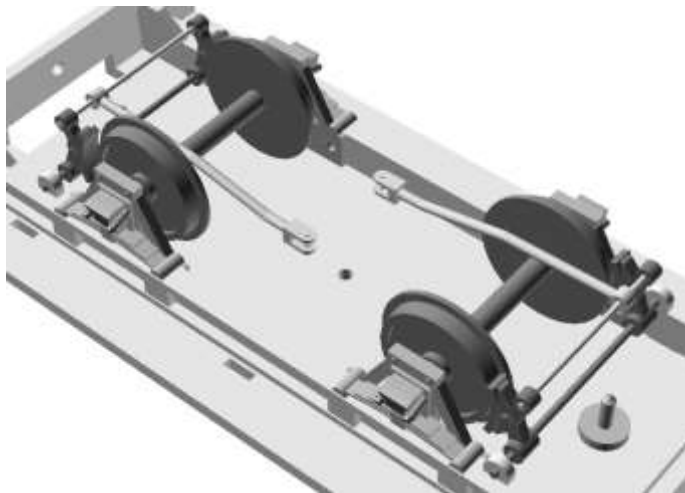
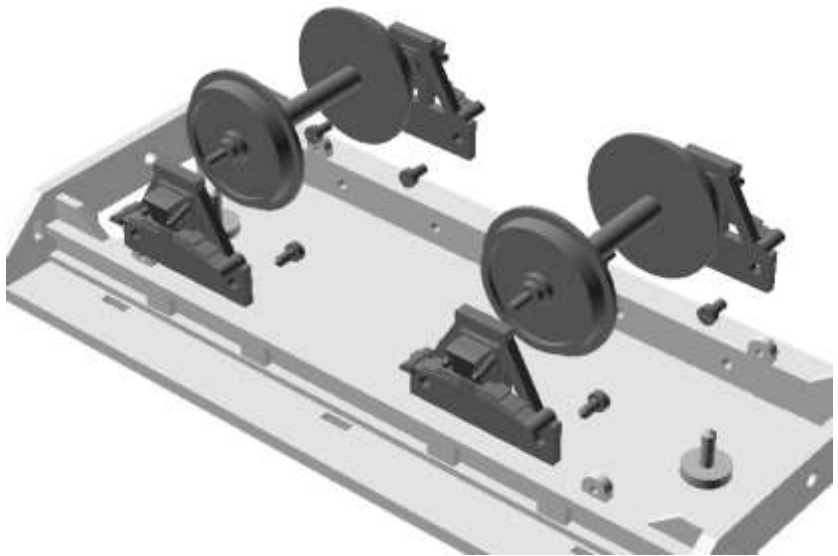

Slide one of the steel brake rods through a brake hanger hole, through the larger bosses of a pair brake shoes and finally through the opposite brake hanger. Adjust the brake shoes so they are in line with the wheel treads but outside of the rims. Tread a length of brass rod through the other shoe bosses and the link arm boss and trim to length. **N.B. the link arm is slightly cranked and the central end is closer to the floor**

Next glue the brake crank to the inside of the buffer beam as shown. **N.B. It should be right at the edge of the beam as shown.** Glue the central pivot post in place as shown. Now place the central fulcrum arm on its pivot and clip the two link arms to it. Finally clip the long link arm in place between the crank and fulcrum arm.

Check brake shoe clearances and then secure brake linkages with a few spots of glue on the various pivot points.

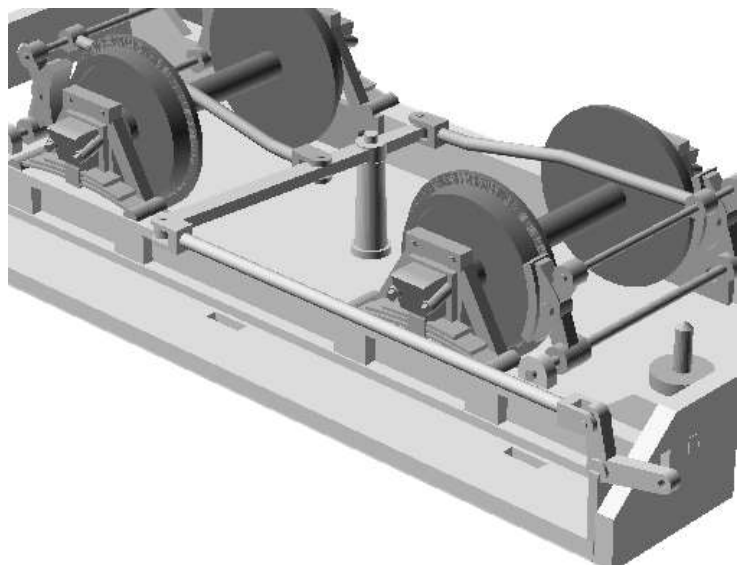

Step 4 - Body

First “de-burr” the body sides and ends by gently stroking the emery board across both faces of the styrene body side. Also ensure all the rivet holes are free of any “nubs” left by the laser cutter. Temporarily push the “angle irons” into their rivet holes to ensure they sit flat on the body sides.

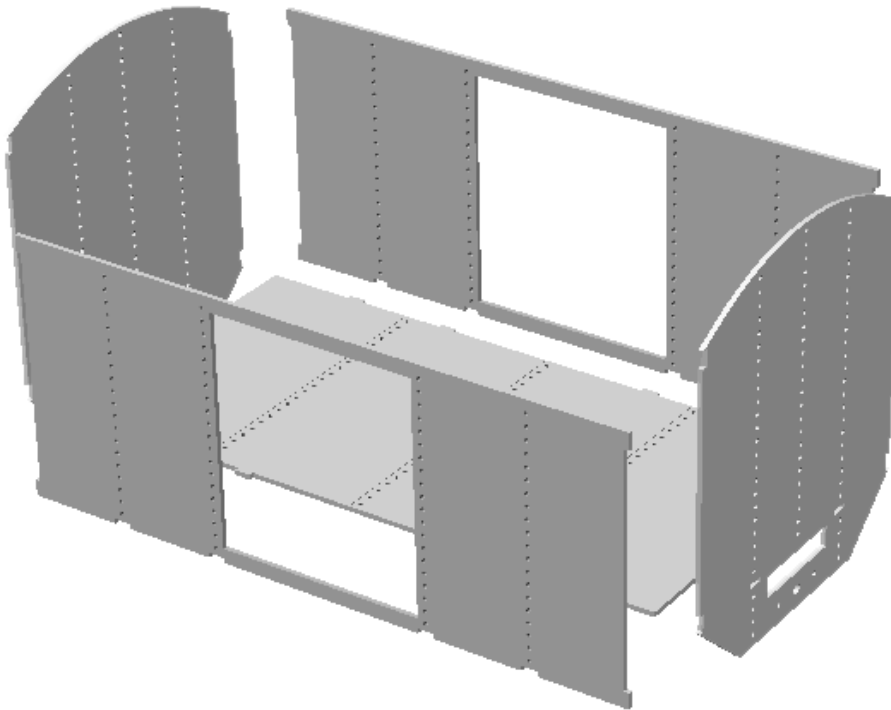

Glue the sides and ends to the body floor. Liquid styrene cement (e.g. MEK) works well here but super glue will do. Make sure the rivet detail on the floor faces upward!

Clean the door hinge pivots out with a very small drill bit or fine reamer.

Glue four side straps (two plain, two with hinges) onto the body sides. Ensure the “angle irons” sit flush on the body side. Fix with super glue

Note orientation of the angle irons

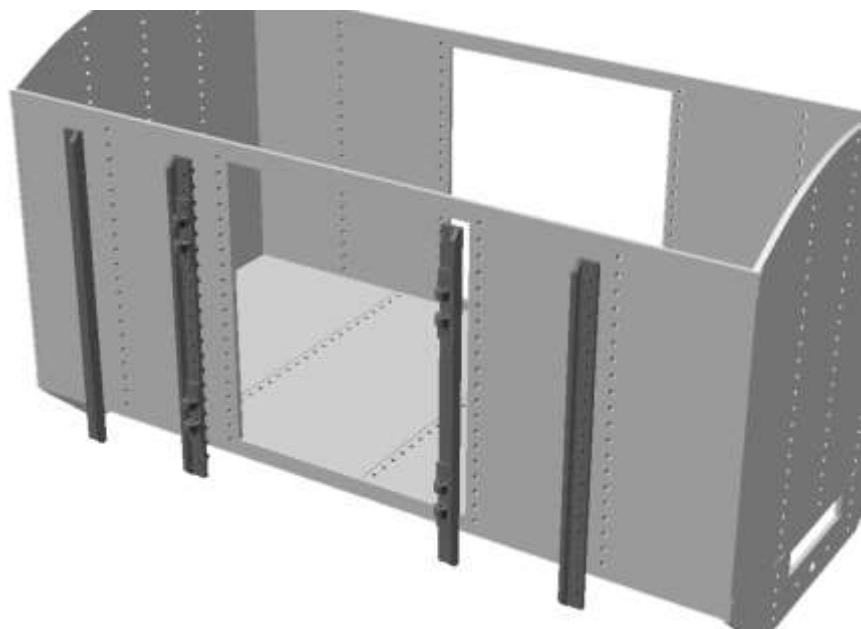

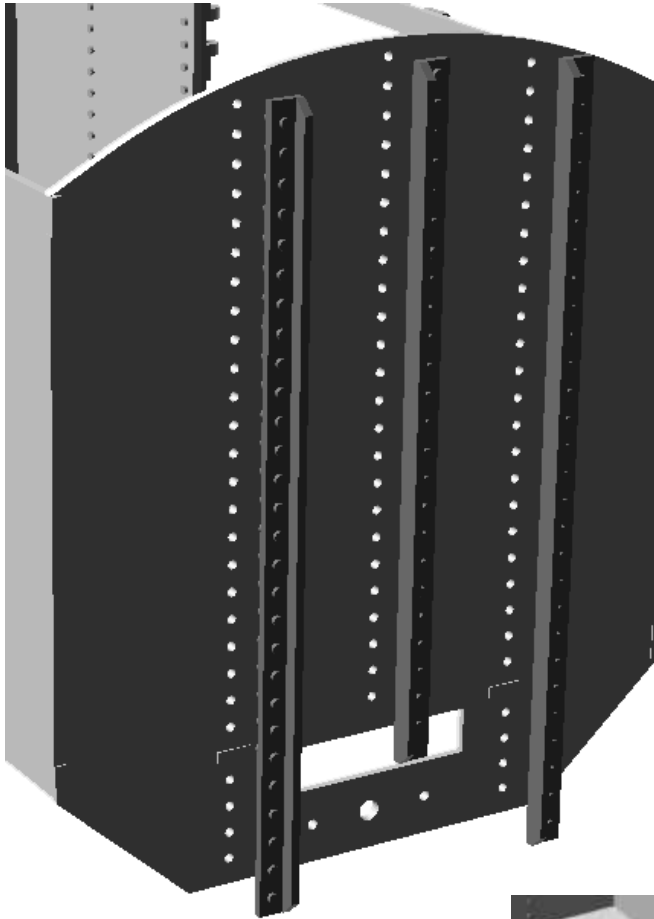

Glue the end straps in place. Note there are left and right hand end straps. Glue a shorter side strap in the middle. **Again note the orientation of the straps which is important for fitting the brake lever later.**

Glue the four cranked corner plates in place.

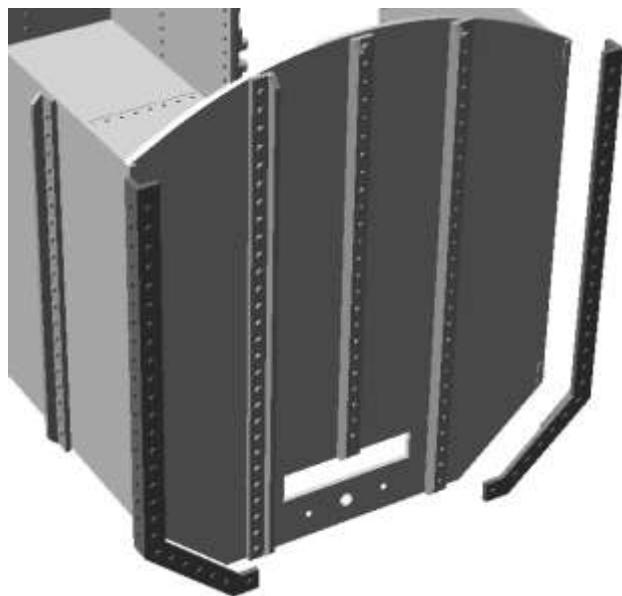

Clean the door hinges out with a very small drill bit or fine reamer. Glue the door straps to the doors with super glue or epoxy.

Note the orientation of the "latch" on the right-hand door.

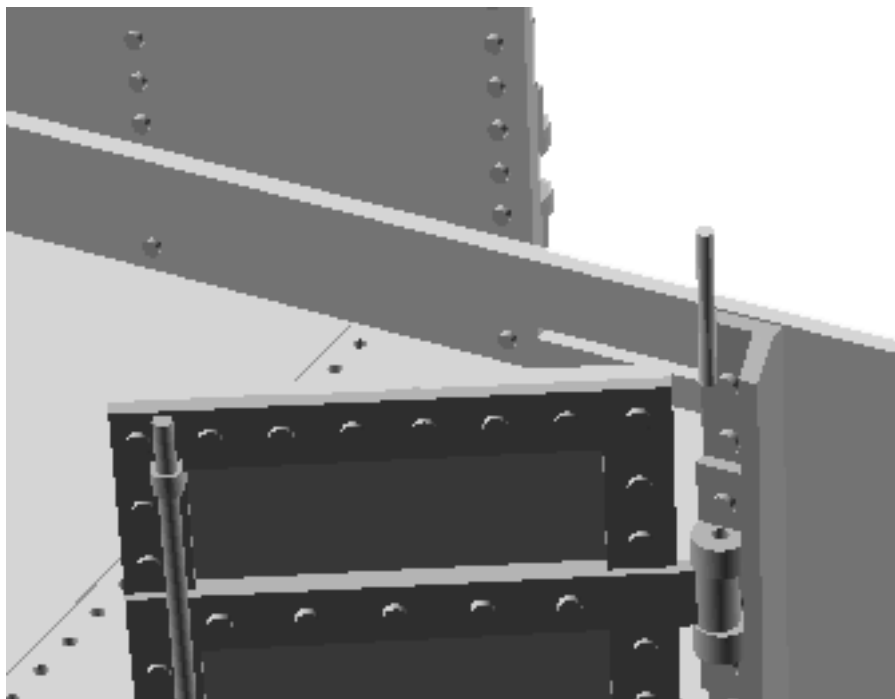
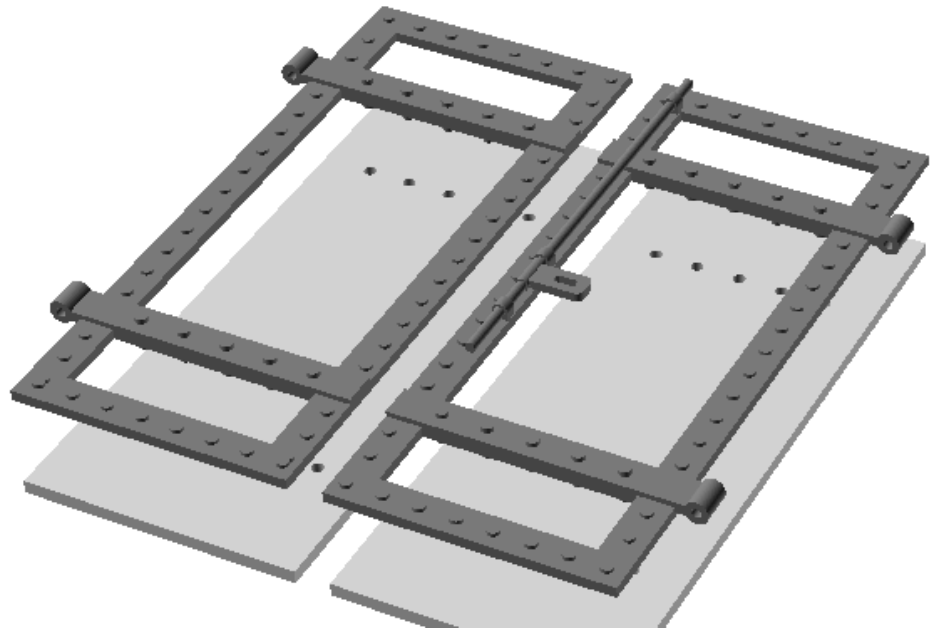

Cut eight 12 mm lengths of brass wire. Attach the doors to the door frames by carefully inserting the brass pivot wires through the 3 holes. If necessary secure with a drop of super glue to an outer end of the pivot wires

Step 5 – Couplings

We include three coupling options with this kit. Assemble the two drawbars for your selected option.

A) Prototypical swing link and pin

Bend up a simple wire hooks and glue into the vertical holes at the end of one drawbar trapping an oval coupling link in place. Glue a short length of brass wire into a coupling pin head. When coupling up your train swing the link from one wagon into the other wagons “empty” drawbar and drop link through holes to trap coupling link. Non DHR stock can be coupled with a 3-link chain over the hook with the trapped coupling link swung sideways out of the way.



B) Drop link and hook

Attach the long coupling shackles to the draw bars by passing a 10mm length of the supplied fine brass wire through the horizontal holes in the drawbars. Retain with a spot of glue on the outsides. Bend up a pair of simple wire hooks and glue into the vertical holes at the end of the both drawbars.



Wagons may be coupled by dropping one of the shackles over the other wagons hook.

C) Hook and chain

Bend up a pair of simple wire hooks and glue into the vertical holes at the end of both drawbars. You will be able to couple the wagons together by using a 3 link chain.

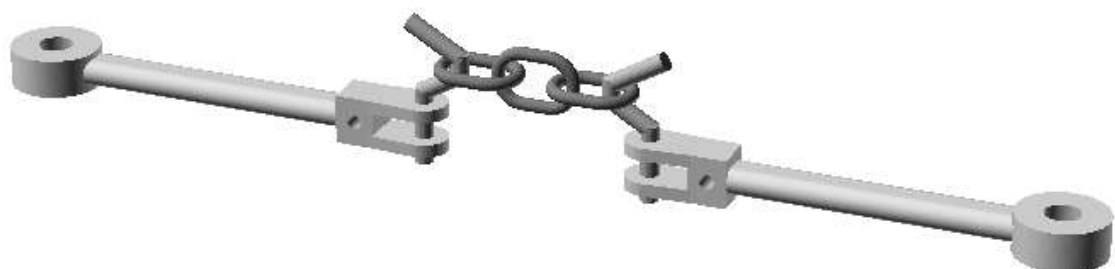

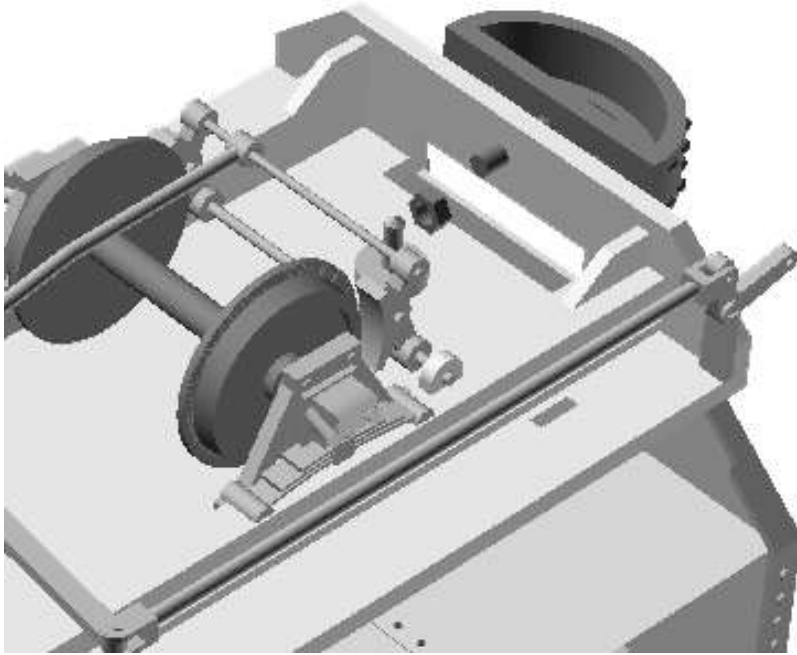

Thread a M3 hex head bolt into each of the buffers. Place the body onto the chassis and secure by pushing the M3 bolt through the central holes and securing behind with a M3 nut.

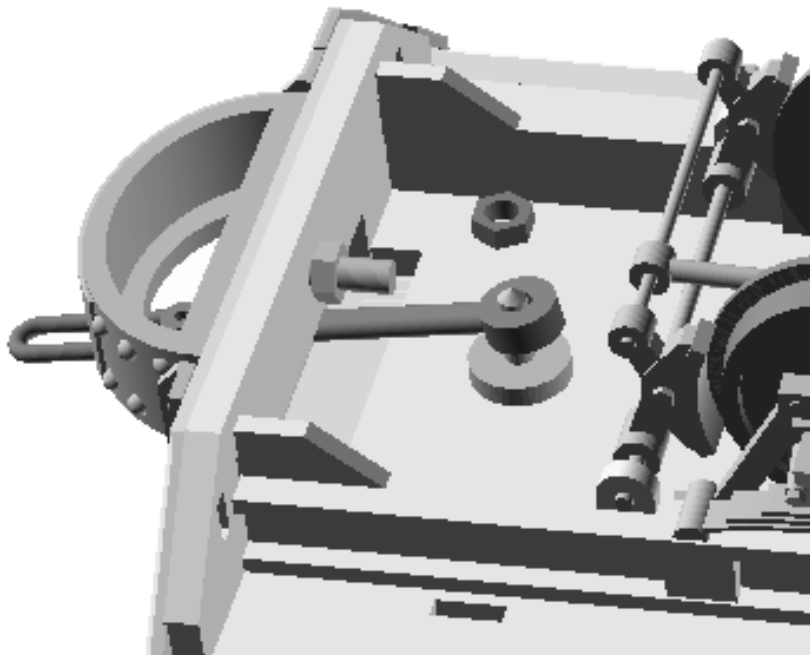

Thread the drawbars through the slots in the body above the buffers and place the pivot bosses over the pivot bolts. You may have to widen the pivot hole with a 3mm drill bit to do this.

When in place, secure with a M2.5 nut. Tighten the nut so the draw bar is just free to pivot. Add a drop of thread lock or paint to stop the nut working loose.

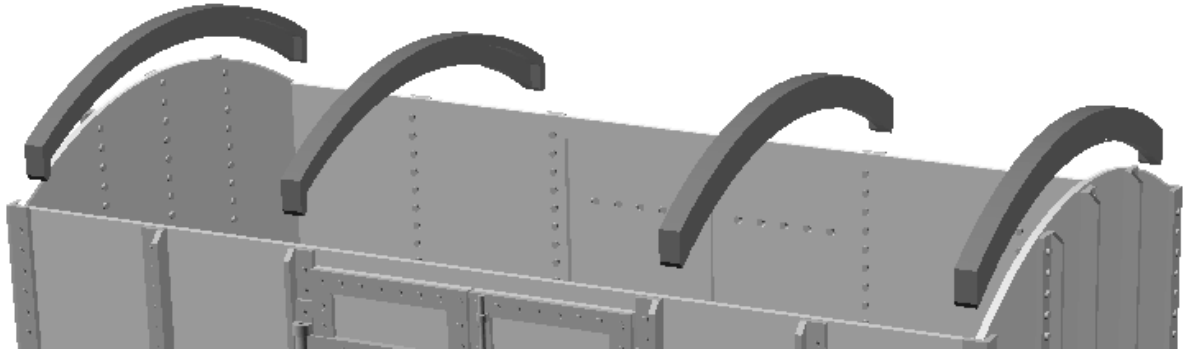

Glue the four roof supports in place. The sides of the end supports should be glued to the body ends to give a nice firm joint.

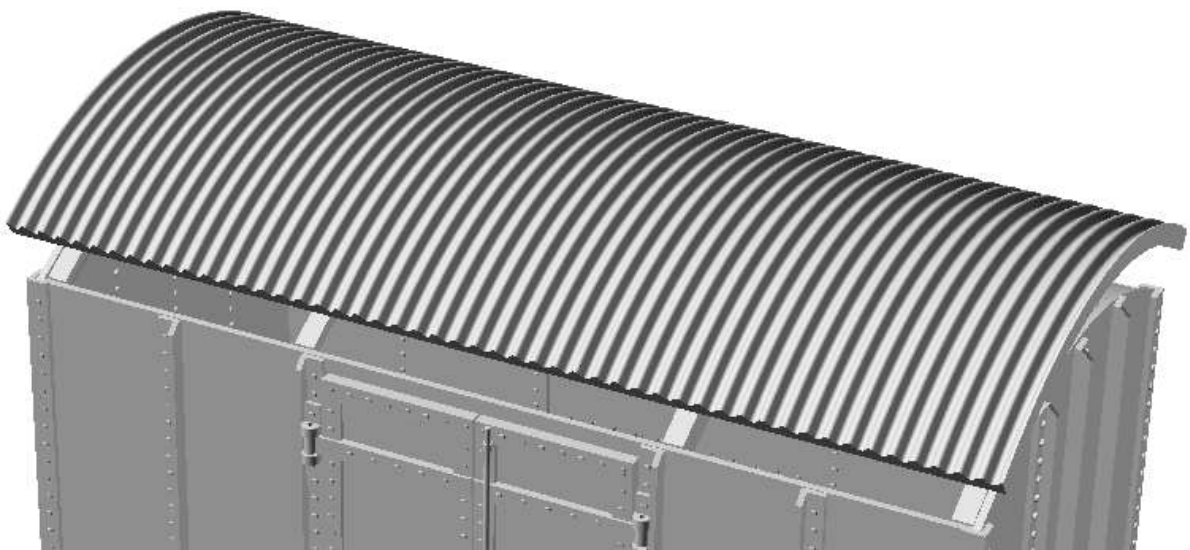

Trim the vacuum formed roof sheet to size and glue to the four roof supports with something like epoxy resin.

Step 6 – Brake lever (optional)

Finally thread the brake lever through the ratchet plate and clip on the end link. Glue the brake lever, ratchet plate and pivot plate in place on the end with the brake crank.

N.B. the ratchet plate should be on the body end hard up against the angle iron.

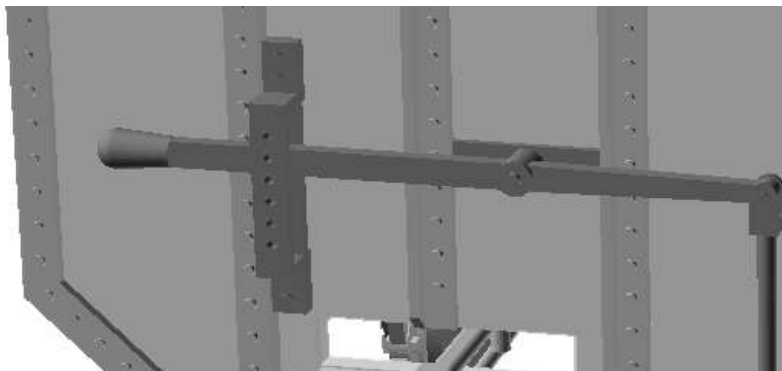
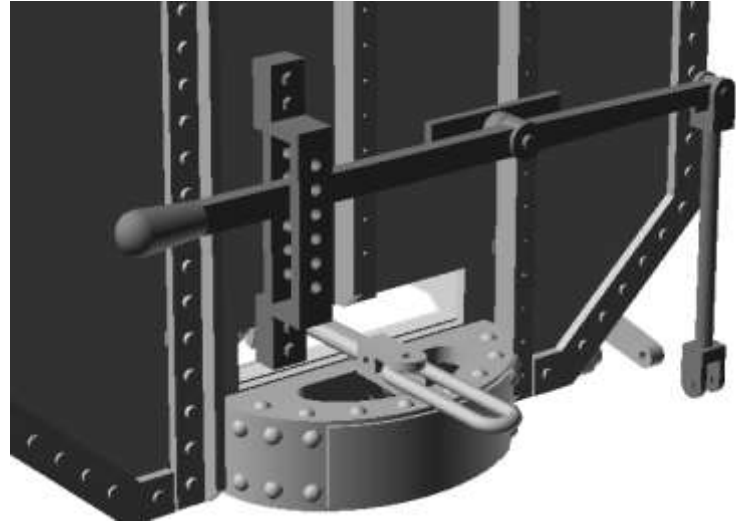

Glue the hand rail at the top of the brake end. N.B. you may find it easier to trim off a couple of rivet heads on the “angle iron” so that you get a flat surface to glue to.

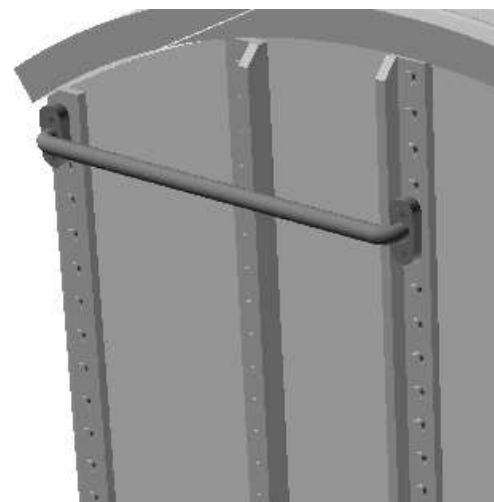

Finished!

Packing List

Part	Quantity	
Chassis Fret (3mm MDF)	1	
3D printed solebars	2	
Nut plate fret (0.5 mm styrene)	1	
<i>Body parts</i>		
Floor (1.5mm styrene)	1	
Body sides (1.5mm styrene)	2	
Body ends (1.5mm styrene)	2	
Roof supports (black 3D printed PETG)	4	
Roof (vacuum formed styrene)	1	
<i>Details</i>		
Wagon strapping set (white SLS nylon)	2	
DHR Axle guard pair (black SLS nylon)	2	
Buffer pair (black SLS nylon)	1	
Draw bar set (black SLS nylon)	1	
<i>Bits Bag</i>		
M2 6mm screws	8	
M2 nuts	8	
M2.5 10mm screws	2	
M2.5 nuts	2	
M3 10mm bolts	2	
M3 nuts	2	
Door Hinge wire (80mm long 0.8mm dia brass wire)	1	
Coupling wire (75mm long 1.2 mm dia brass wire)	1	
Coupling chain	2	
<i>Optional Brake Detail set</i>		
Brake lever set (black SLS nylon)	1	
Brake rods, 32mm gauge (54mm long 1.5 mm dia piano wire)	2	
Brake rods, 45mm gauge (65mm long 1.5 mm dia piano wire)	2	
Brake Hinge wire (100 mm long 1.2 mm dia)	1	